

300 Old Pretoria Road Albany, GA 310721
Phone: 229-883-1440 Fax: 229-439-9790
www.thrushaircraft.com

SERVICE BULLETIN

No. SB-AG-71

Initial Release: 04/09/2019

S2R-T34 MVP & GCU WIRING RELOCATION

AIRPLANES AFFECTED:

MODEL

SERIAL NUMBERS

S2R-T34

ALL

A handwritten signature in blue ink, appearing to read "Levan Tabidze", written over a horizontal line.

Levan Tabidze

Vice President of Engineering

LOG OF REVISIONS

NOTE: Reformatting and correction of typographical errors is not considered revision. True revisions are indicated by a dark vertical line at the right margin of the lines revised.

Rev.	Page	Description of Revision	By:
IR	All	New Document Initial Release.	K. Sheppard 04/09/2019

Contents

1. PURPOSE/REASON FOR PUBLICATION:.....4
2. SCOPE/COMPLIANCE:.....4
3. BY WHOM WORK WILL BE ACCOMPLISHED:.....4
4. APPROVAL:.....4
5. MAN HOURS:4
6. SPECIAL TOOLS:.....4
7. REPAIR/MODIFICATION:5
8. RECORD OF COMPLIANCE:.....8
9. RESPONSE CARD8

1. PURPOSE/REASON FOR PUBLICATION:

The purpose of this Service Bulletin is to improve battery life and redistribute terminals on relay posts.

2. SCOPE/COMPLIANCE:

This Service Bulletin is highly recommended for all S2R-T34 airplanes equipped with GCU and MVP installed.

3. BY WHOM WORK WILL BE ACCOMPLISHED:

The work is to be accomplished by a FAA Certified A&P mechanic or foreign equivalent.

4. APPROVAL:

This Service Bulletin is approved by the Vice President of Engineering at Thrush Aircraft, Inc.

5. MAN HOURS:

2 hours will be required.

6. SPECIAL TOOLS:

No special tools required

7. REPAIR/MODIFICATION:

- 1) Remove cowling shown in Figure 1.



Figure 1
510P Cowlings

- 2) Disconnect Batteries. See Figure 2.



Figure 2
510P Battery Location

- 3) Remove wires 29043-156-4 & 29043-910-20 from the B stud of the Master Relay located at the battery plate. See Figures 2 and 3.

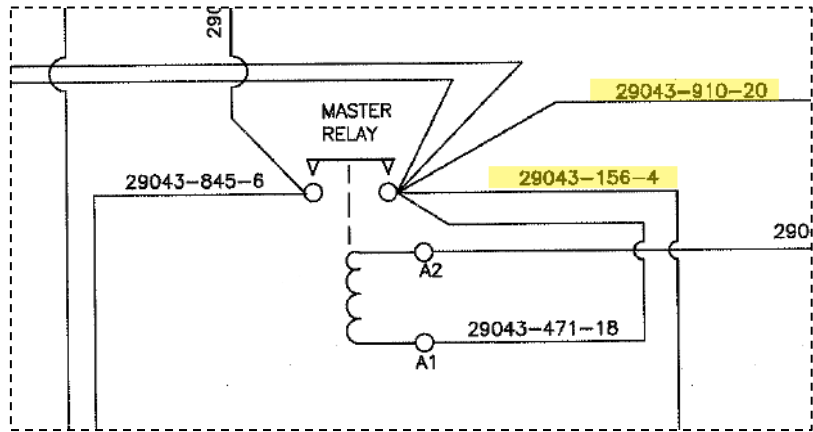

Figure 2
Original Schematic

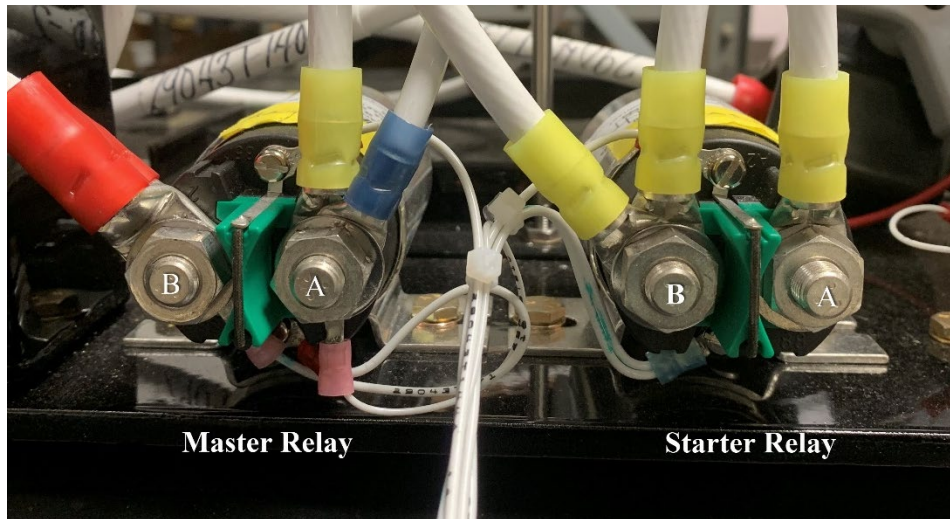

Figure 3
Master & Starter Relay

- 4) Reroute wires 29043-156-4 & 29043-910-20 to the A stud of the Master Relay. See Figure 3 and 4.
- 5) Reuse hardware and be aware not to deform the terminal lugs or the studs while installing.

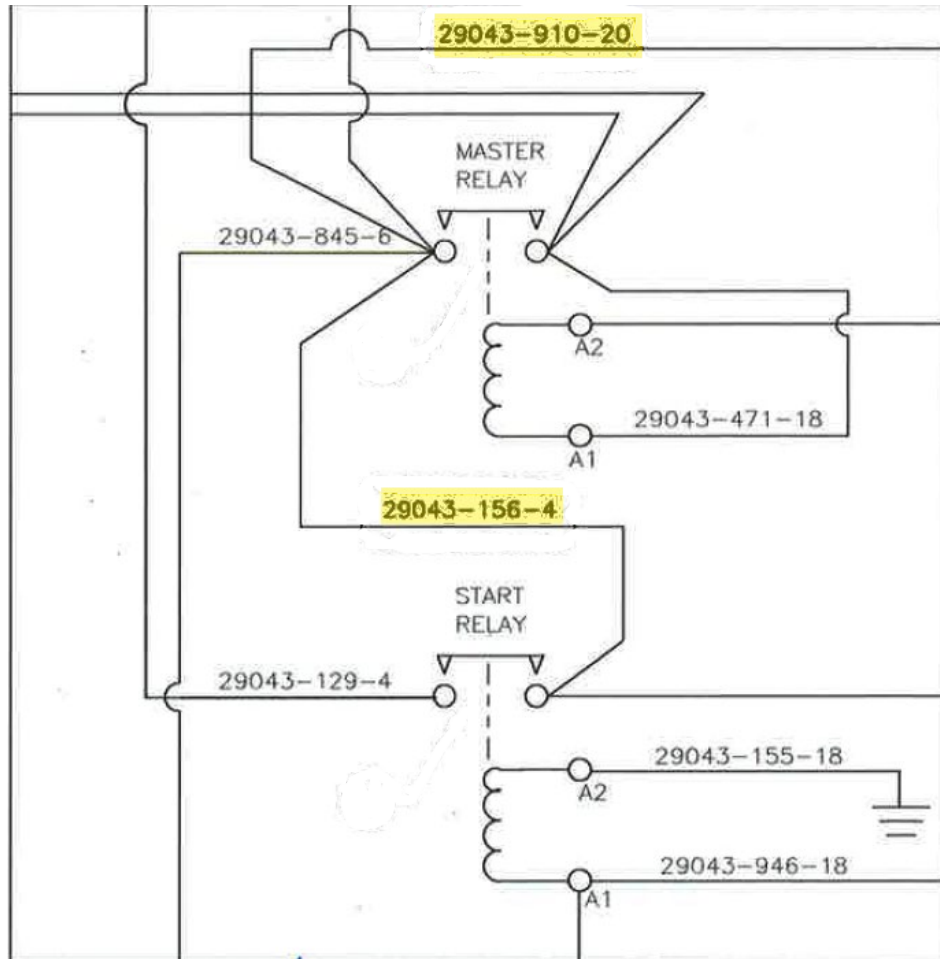

Figure 4
New Schematic

- 6) Reconnect battery. To charge the battery, the Battery Switch must be on.

8. RECORD OF COMPLIANCE:

Make appropriate entry in airplane maintenance records as follows:

“Thrush Service Bulletin SB-AG-71 Rev. IR complied with at _____ total hours on aircraft.”

Modification accomplished by:

Name & Certificate #	Date
----------------------	------

9. RESPONSE CARD

The final step in compliance with this Service Bulletin is to complete and return the compliance card on the next page. It may be mailed, Faxed, or scanned and e-mailed.

Fax to:	Ed Rusk	229-439-9790
Email to:	Ed Rusk	erusk@thrushaircraft.com

Service Bulletin SB-AG-71 Rev. IR Compliance Report

Aircraft S/N:	Aircraft Owner:
Aircraft Registration #:	Address of Owner:
Airframe total time:	City & State:
Engine total time:	Physical location:
Complied with by:	Date of Compliance:
Signature:	Certificate #:

PLEASE RETURN THIS REPORT ONLY AFTER MODIFICATION IS MADE

This response card may be mailed, faxed to (229) 439-9760, or emailed to erusk@thrushaircraft.com.

Fold, Tape & Mail (Do Not Staple)

Return Address

Thrush Aircraft Inc.
 Attn: Ed Rusk
 300 Old Pretoria Road
 Albany, Ga 31721